

SUPERPOSITION DATA TRANSMISSION FOR COGNITIVE RADIOS: PERFORMANCE AND ALGORITHMS

Heejung Yu, Youngchul Sung and Yong H. Lee

Department of Electrical Engineering
Korea Advanced Institute of Science and Technology, Daejeon, Korea
E-mail: hjyu@stein.kaist.ac.kr; {ysung, yohlee}@ee.kaist.ac.kr

ABSTRACT

For improvement of achievable rate region in cognitive radio channels, a transmission method for secondary users is proposed. At first, the rate region of the sensing based cognitive radio scheme in which secondary users access the channel based on their channel sensing results with sensing error is analyzed. In the multi-user information theory, it is well-known that interference channel cases where both users transmit their own signal simultaneously achieve better rate region than the time-sharing method based on sensing outcomes. Based on this theoretical result, we propose the new transmission scheme in which a secondary transmitter relays primary user's signal with a full-duplex amplify and forward (AF) manner while transmitting its own data at the same time. In the proposed method, we take account of practical implementation issues which are ignored in the theoretical method guaranteeing an upper bound of a rate region. With different geometric locations and power ratios between the relaying signal and the secondary user's one, we evaluate the achievable rate region of the proposed method and compare with those of the conventional ones.

Index Terms – Cognitive radio, achievable rate region, interference channel

1. INTRODUCTION

As available frequency bands become scarce, cognitive radios have been proposed to maximize the spectrum utilization [1, 2]. Moreover, this technology has been considered as one of key technologies for the next generation wireless communication. Cognitive radios can opportunistically use the frequency bands which is assigned to the licensed users if secondary users' links do not interrupt the licensed (primary) users' links. As an example, the secondary users access a channel after sensing it to check the channel vacancy

work was partly supported by the IT R&D program of MKE/IITA [2008-F-004-01, 5G mobile communication systems based on beam division multiple access and relays with group cooperation] and Samsung Advanced Institute of Technology.

in IEEE 802.22 wireless regional area network (WRAN) systems defined in the ultra high frequency (UHF) TV bands [3]. Thus, this is regarded as a time-sharing scheme where two users access a given channel with a time division manner depending on sensing results. Therefore, the primary and secondary rates of such cognitive radio systems are determined by channel sensing performance including false alarm and detection probabilities. Even though the secondary users can know the channel status perfectly, channel utilization method with a time-sharing manner is not optimal in terms of the multi-user channel capacity. Channel access schemes for both users to transmit simultaneously can guarantee the better achievable rate region than the time-sharing channel access scheme. From this fact, we proposed a new channel access method for secondary users in cognitive radios. Instead of using a channel depending on channel sensing outcomes, a secondary transmitter amplifies and forwards the received primary user's signal with a full-duplex manner while transmitting its own signal. Using this scheme, interference increment caused by the secondary signal to a primary link will be compensated with the AF relayed primary signal. With this approach, we can achieve the improved rate region than the conventional sensing based approach. Additionally, we can avoid the rate loss due to abnormal operations like miss detection and false alarm events in a sensing based method. The proposed method can be efficient both in transmitting periodic control information and in guaranteeing quality of service (QoS) because a secondary user can transmit data regardless of primary user's channel occupancy.

1.1. Related Works

Simultaneous transmission of primary and secondary users can be regarded as an interference channel model and it achieves improved rate region over the conventional time-sharing method. In [4, 5], authors introduced the cognitive radio transmission methods which can maximize the throughput with several assumptions. In detail, S. Srinavasa et al. proposed a secondary user's operation policy to trans-

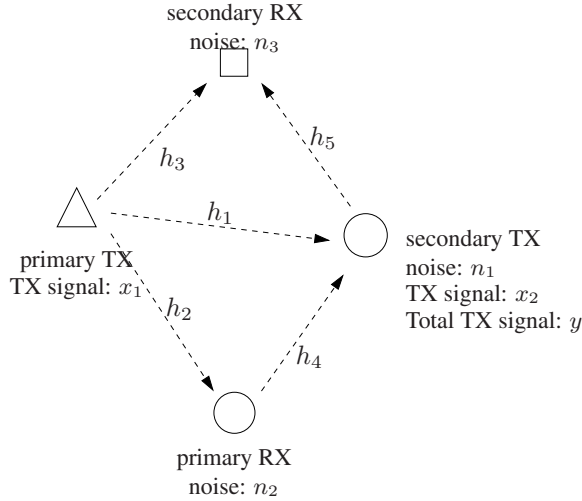

Fig. 1. Cognitive radio system model.

mit primary user's signal as well as its signal with appropriate power ratio to improve an achievable rate region [4]. This method, however, includes two unrealistic assumptions. First, the primary user's transmit data should be known at a secondary transmitter. Next, the dirty paper coding (DPC) technique is employed to mitigate interference effects coming from a primary transmitter to a secondary receiver. The first assumption is impossible one in practice and the last one is too complex to implement. For these reasons, the cognitive radio scheme proposed in [4] gives the only theoretical upper bound of an achievable rate region. In this paper, we propose a new cognitive radio transmission method without any non-practical assumption.

1.2. Main Results

To approach the theoretical upper bound in practical systems, the unrealistic assumptions which are needed for achieving the bound should be relieved. Hence, we use the full-duplex AF relaying method to eliminate the data sharing assumption and the interference cancellatoin reception instead a DPC technique. In the proposed scheme, the noise added at the secondary transmitter produces performance loss from the upper bound.

2. SYSTEM MODEL

We consider a cognitive radio network with two transmitter-receiver pairs, as shown in Fig. 1, to simplify the problem and gain insights into the capacity region enhancement. Five possible channel links between two nodes are defined with $h_i, i = 1, \dots, 5$. x_1 and x_2 denote primary and secondary users' signal and the transmit power is normalized. Moreover, additive white Gaussian noise (AWGN) terms at

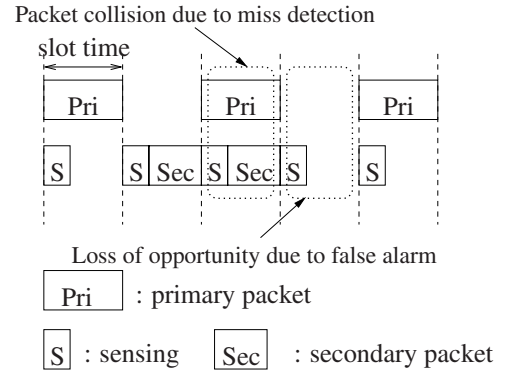

Fig. 2. Operation example of sensing based cognitive radios.

the secondary transmitter, the primary receiver and the secondary receiver are represented by n_1, n_2 and n_3 , respectively. The variance of these three noise terms are σ_1^2, σ_2^2 and σ_3^2 . At a secondary transmitter, the received primary signal is amplified and forwarded with a gain g and total delay D which includes propagation delay and processing time. The total transmit signal from a secondary transmitter consists of the secondary user's signal and the AF relayed primary signal, and the total transmit power is allocated to two parts with power ratio θ and $1 - \theta$. Further, we assume that primary and secondary transmitters have always packets to transmit.

3. ACHIEVABLE RATE REGION OF SENSING BASED COGNITIVE RADIO

Before introducing the proposed scheme and its capacity, we analyze the achievable rate region of the conventional cognitive radio with spectrum sensing. For the simple analysis, we assume that transmission is slotted with slot interval of T and the primary and secondary users are synchronized. For each slot, the primary transmitter sends a packet to its receiver independently with probability γ . The secondary transmitter senses a channel to check the channel vacancy with sensing interval T_s . If the channel is not used by the primary user, the secondary user transmits its own signal for the remaining time $T - T_s$. Otherwise, it waits until the channel is available for transmission. These operation scenario of cognitive radio systems are illustrated in Fig. 2.

If channel sensing is normally operated, the secondary user accesses in the time slot when the primary user does not use a channel. However, there are two kinds of abnormal cases like false alarm and miss detection events. In the false alarm case, the secondary user misunderstands an idle channel as a busy one. Hence, this can be regarded as loss of an opportunity for the secondary user to use the channel. On

the other hands, the miss detection means that a secondary signal interferes with primary signal so the both corresponding receivers cannot decode any packet. From these facts, The capacities of the primary and secondary users are given by [6]

$$C_{pri} = \gamma\beta(\alpha, T_s)C_p \quad (1)$$

and

$$C_{sec} = (1 - \gamma)(1 - \alpha)\frac{T - T_s}{T}C_s \quad (2)$$

where, α means a false alarm probability of a channel sensor in a secondary transmitter and $\beta(\alpha, T_s)$ denotes a detection probability with a given false alarm probability α and sensing interval T_s at given signal to noise ratio (SNR). Furthermore, $C_p = \log_2\left(1 + \frac{|h_2|^2}{\sigma_2^2}\right)$ and $C_s = \log_2\left(1 + \frac{|h_5|^2}{\sigma_3^2}\right)$ represent channel capacities when the corresponding users occupy a given channel, respectively. Here, a detection probability depends on channel sensing methods like energy detection and matched filter. When the primary signal pattern is unknown, an energy detection is used in general. However, it has significantly worse detection performance than a matched filter at the same SNR. In detail, it is known that the error rate of the matched filter decays, as a function of SNR, with rate $\exp(-\frac{1}{2}\text{SNR})$ while that of the energy detector decreases with rate $\exp(-\frac{1}{2}\log \text{SNR})$ [7, 8]. Further, an energy detection has the fundamental performance limit due to inaccurate noise power estimation [9]. Hence, the matched filter detection is employed for channel sensing in this paper with assumption that the know pilot pattern is embedded in the primary signal. In a matched filter case, a detection probability is given by

$$\beta(\alpha, T_s) = Q\left(Q^{-1}(\alpha) - \sqrt{T_s \frac{|h_1|^2}{\sigma_1^2}}\right) \quad (3)$$

where, $Q(\cdot)$ is the Gaussian tail probability¹ and $\frac{|h_1|^2}{\sigma_1^2}$ is SNR of a channel sensor at a secondary transmitter. As shown in (1) and (2), an operation point $(\alpha, \beta(\alpha, T_s))$ on a receiver operation characteristics (ROC) curve of a channel sensor determines the capacity of cognitive radios. An achievable rate region of the conventional cognitive radio based on channel sensing can be written as

$$(C_{pri}, C_{sec}) = \left(\gamma\beta(\alpha^*, T_s)C_p, (1 - \gamma)(1 - \alpha^*)\frac{T - T_s}{T}C_s\right) \quad (4)$$

where

$$\alpha^* = \arg \max_{\alpha} (C_{pri} + C_{sec}). \quad (5)$$

In imperfect sensing cases, rate region depends on a false alarm probability as shown in Fig. 3. Each dotted line represents a rate region with one fixed false alarm probability.

¹ $Q(x) = \int_{-\infty}^x \frac{1}{\sqrt{2\pi}} \exp(-0.5t^2) dt$

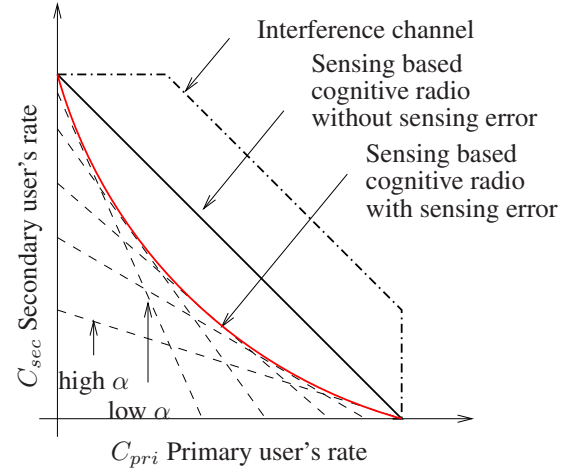

Fig. 3. Achievable rate region of sensing based cognitive radios.

Therefore, the achievable region determined by (4) is given by the curve tangent to all dotted straight lines with different false alarm probabilities as shown in Fig. 3. As an extreme case, we can also consider the perfect channel sensing, i.e. $\alpha = 0$ and $\beta(\alpha, T_s) = 1$. In this case, an achievable rate region is defined with a straight line connecting between $(C_p, 0)$ and $(0, \frac{T-T_s}{T}C_s)$.

In the multi-user information theory, interference channels in which two users access the same channel simultaneously show better rate region than a time-sharing channel access where users utilize a channel exclusively and have the achievable region shown in Fig. 3 [10]. Hence, primary and secondary users in cognitive radios should share the same channel at the same time to enhance the throughput.

4. THEORETICAL COGNITIVE RADIO SCHEME GUARANTEEING ACHIEVABLE RATE REGION

In [4], authors introduced a cognitive radio transmission scheme maximizing an achievable rate region. The detail operation of each transceiver is shown in Fig. 4. In general, primary users have a license to use a given channel so their operation scenarios cannot be changed. At a secondary transmitter, however, secondary signal is transmitted with the fractional transmit power even though a primary users use the same channel at the same time. The remaining transmit power of the secondary transmitter is used to send the primary signal with assumption primary user's data is known to both primary and secondary transmitters. Hence, the secondary transmitter sends primary and its own signal with power ratio θ and $(1 - \theta)$ as shown in Fig. 4. To eliminate interference caused by the primary signal at the secondary receiver, a DPC technique is employed in the sec-

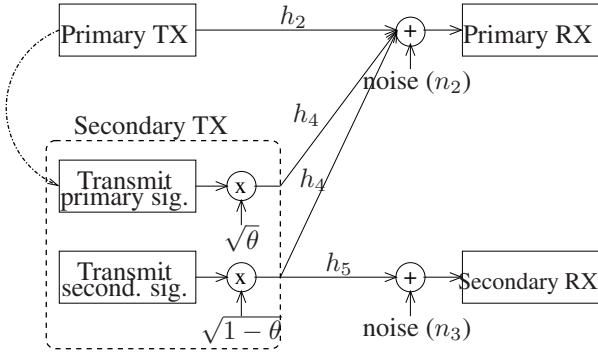

Fig. 4. Theoretical cognitive radio scheme guaranteeing achievable rate region.

ondary transmitter. Therefore, the capacity of the secondary link is defined as

$$C_{sec} = \log_2 \left(1 + \frac{(1-\theta)|h_4|^2}{\sigma_3^2} \right). \quad (6)$$

On the other hands, the primary receiver regards the secondary interference signal as noise and decodes with a conventional manner. Some part of the secondary transmit signal is the desired one, the other is the interference. Hence, we can say that the extra transmission of the primary signal from the secondary transmitter is used to compensate the SNR loss of the primary link due to the secondary interference signal. The primary link capacity is given by

$$C_{pri} = \log_2 \left(1 + \frac{|h_2|^2 + \theta|h_4|^2}{(1-\theta)|h_4|^2 + \sigma_2^2} \right). \quad (7)$$

To obtain the above capacities, two non-practical assumptions are required.

(AS1) *In spite of geometrical separation of primary and secondary transmitters, the secondary transmitter knows the primary user's data without any delay.*

(AS2) *A DPC method is used to cancel the primary interference signal which degrades the quality of a secondary link.*

The first assumption **(AS1)** cannot be satisfied at all in practical systems. In the case of the second assumption **(AS2)**, its implementation is possible but it requires too much complexity. Authors in [4] did not mention but one more assumption should be included in addition to **(AS2)** to perfectly eliminate the primary interference. Though a DPC method is applied in a secondary transmitter, interference effects due to a primary user's data is not perfectly cancelled because the primary signal from a primary transmitter cannot be eliminated. For perfect interference cancellation, the channel state information between a primary transmitter and a secondary receiver should be available at a secondary transmitter.

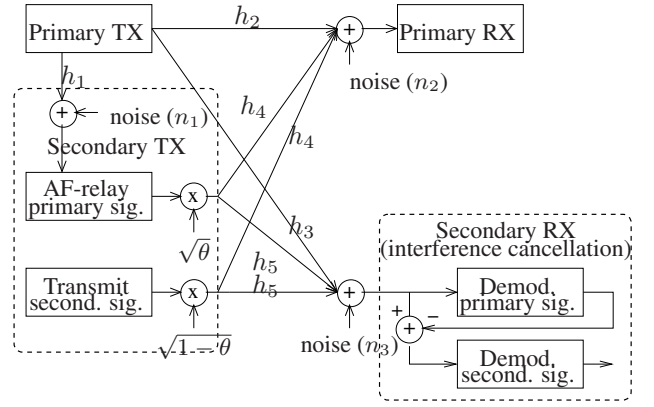

Fig. 5. Proposed transmission scheme for cognitive radios.

We can guarantee the improved achievable rate region with this method. However, we have to solve the above two assumptions to realize the improved rate region. In this paper, a new cognitive radio scheme which achieves better rate region than the conventional sensing based time-sharing scheme without any unrealistic assumption is proposed.

5. PROPOSED COGNITIVE RATIOS

In this section, we propose the new cognitive radio transmission scheme for improvement of a achievable rate region. As in the theoretical method explained in the above section, a secondary transmitter not only relays the primary received signal but also sends its own data with power ratio θ and $(1-\theta)$. To remove the first assumption **(AS1)** in the theoretical method, a secondary transmitter amplifies and forwards the received primary signal with a full-duplex manner. To minimize the rate loss due to relaying, a full-duplex scheme is preferable because a half-duplex one requires twice time slot to relay a packet. By employing an AF method, the waveform of the primary signal instead of the primary user's data is available at a secondary transmitter and it is helpful to enhance the capacity. Because the received primary waveform is the distorted version of the primary signal including noise and channel effects, we cannot avoid the performance degradation against the theoretical method using the non-distorted primary data. With the same reason, a DPC scheme cannot be applied at a secondary transmitter and interference cancellation cannot be applied at the secondary transmitter. To decode the desired secondary signal at a secondary receiver, we decode the primary signal at first, cancel it, and then decode the desired secondary signal. The proposed method can be summarized with Fig. 5.

The transmit signal from the secondary transmitter is

written by

$$y[n] = \sqrt{\theta}gh_1x_1[n-D] + \sqrt{1-\theta}x_2[n] + \sqrt{\theta}gn_1[n-D] \quad (8)$$

where $g = \frac{1}{\sqrt{h_1^2 + \sigma_1^2}}$ for normalization of the transmit power. D denotes a delay between the relayed signal and the direct link signal. Since D can be regarded as a delay due to multi-path channels, it does not introduce any performance loss but can be benefit because of time diversity gain.

The received signal at a primary receiver is given by

$$\begin{aligned} r_1[n] &= h_2x_1[n] + h_4y[n] + n_2[n] \\ &= h_2x_1[n] + \sqrt{\theta}h_4gh_1x_1[n-D] \\ &+ \sqrt{1-\theta}h_4x_2[n-D] + \sqrt{\theta}h_4gn_1[n-D] + n_2[n]. \end{aligned} \quad (9)$$

The power of the secondary signal (x_2 terms in (10)) is lower than that of the primary signal (x_1 terms in (10)) so the secondary signal is regarded as noise. If we assume that interference term follows a Gaussian distribution, the primary link capacity is given by

$$C_{pri} = \log_2 \left(1 + \frac{|h_2|^2 + \theta g^2 |h_4 h_1|^2}{(1-\theta)|h_4|^2 + \theta g^2 |h_4|^2 \sigma_1^2 + \sigma_2^2} \right). \quad (10)$$

As explained, interference cancellation is performed in a receiver side in the proposed scheme. The received signal at the secondary receiver is written by

$$\begin{aligned} r_2[n] &= h_3x_1[n] + h_5y[n] + n_3[n] \\ &= h_3x_1[n] + \sqrt{\theta}h_5gh_1x_1[n-D] \\ &+ \sqrt{1-\theta}h_5x_2[n-D] + \sqrt{\theta}h_5gn_1[n-D] + n_3[n]. \end{aligned} \quad (11)$$

If the perfect interference cancellation is assumed, we can rewrite the above equation as

$$r_2'[n] = \sqrt{1-\theta}h_5x_2[n-D] + \sqrt{\theta}h_5gn_1[n-D] + n_3[n]. \quad (12)$$

Therefore the capacity of the secondary link is given by

$$C_{sec} = \log_2 \left(1 + \frac{(1-\theta)|h_5|^2}{\theta g^2 |h_5|^2 \sigma_1^2 + \sigma_3^2} \right). \quad (13)$$

Finally, an achievable rate region of the proposed method is given by (C_{pri}, C_{sec}) with different power ratio $\theta \in [0, 1]$. The details about performance are discussed in the next section.

6. NUMERICAL RESULTS

To check improvement of a rate region, we analyze the achievable rate regions of the sensing based conventional cognitive radio, the theoretical method introduced in [4] and the proposed one with given SNR values of wireless links. To

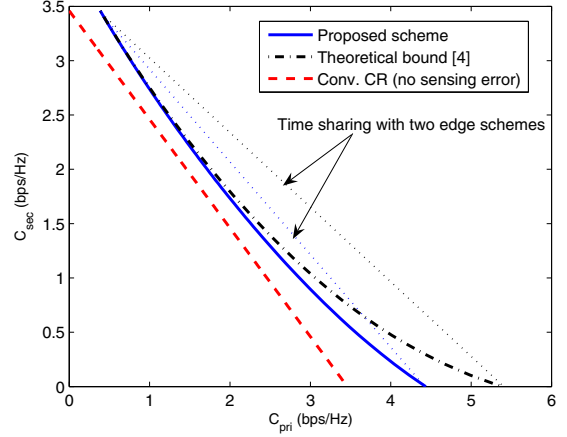

Fig. 6. Achievable rate region comparison when each link SNR is given by $h_1 = 15\text{dB}$, $h_2 = 10\text{dB}$, $h_3 = 15\text{dB}$, $h_4 = 15\text{dB}$ and $h_5 = 10\text{dB}$.

evaluate the rate region of the sensing based time-sharing scheme, we calculate the primary and secondary capacities with different primary channel access probability γ . On the other hands, we use different power ratio values θ for the other two cases.

As a performance comparison condition, SNR of each link is given as follows: h_1, h_2, h_3, h_4 and h_5 links in Fig. 1 have 15, 10, 15, 15, and 10dB SNR, respectively. In this case, h_1 link between the primary transmitter and receiver is better than h_2 link between the primary and secondary transmitters so SNR of the primary link becomes higher because of the AF relayed signal by the secondary transmitter. As shown in Fig. 6, therefore, the proposed method has higher rate than the conventional sensing based one without sensing error for all θ . The performance gap between the proposed scheme and theoretical bound introduced in [4] is caused by an additional noise term which is added in the AF relaying process at the secondary transmitter.

In the other channel condition where SNR of the h_2 link is 20dB and it is better than that of the h_1 link, the rate regions are changed as in Fig. 7. The wireless link between the primary and secondary transmitters has lower SNR than the direct primary link. The AF relayed signal causes harmful effects to SNR of the primary link. Hence, the proposed method shows the worse rate region than the sensing based conventional method as θ goes to 1.

As shown in Fig. 6 and 7, the achievable rate regions of two relay based methods have a concave shape. If we connect two edge point ($\theta = 0, 1$) with a straight line, we can achieve the better rate region. This straight line is achievable if we use the two transmission scheme, i.e. one is ($\theta = 0$) mode and the other is $\theta = 1$ mode, with a time-sharing manner. $\theta = 0$ means that the secondary transmitter

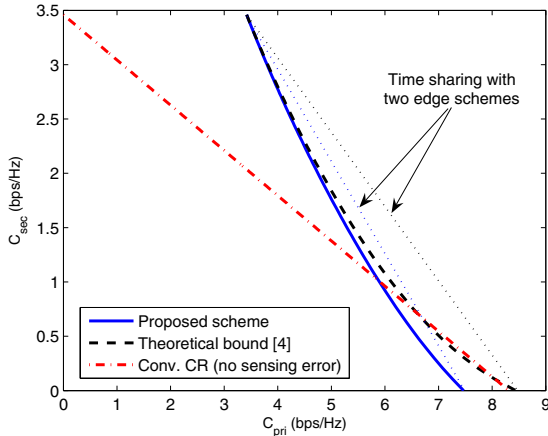

Fig. 7. Achievable rate region comparison when each link SNR is given by $h_1 = 15\text{dB}$, $h_2 = 20\text{dB}$, $h_3 = 15\text{dB}$, $h_4 = 15\text{dB}$ and $h_5 = 10\text{dB}$.

send its own data only and $\theta = 1$ means that the secondary transmitter acts like a relay.

7. CONCLUSIONS

In this paper, we first analyze a achievable rate region of the conventional cognitive radios using a sensing based channel access scheme. To improve the rate region over the sensing based cognitive radios and remove the unrealistic assumptions of theoretical method in [4], we propose the new cognitive radio scheme adopting a full-duplex AF relay and interference cancellation reception. The proposed method can be utilized as a transmission scheme in communication environments where two different communication networks share the same spectrum.

8. REFERENCES

- [1] J. Mitola, "Cognitive radio for flexible mobile multimedia communications," in *Proc. of International Workshop on Mobile Multimedia Communications (MoMuC)*, pp. 3 – 10, Nov. 1999.
- [2] S. Haykin, "Cognitive radio: brain-empowered wireless communications," *IEEE Journal on Selected Area in Communications*, vol. 23, pp. 201 – 220, Feb. 2005.
- [3] IEEE802.22/D0.2, *Draft Standard for Wireless Regional Area Networks Part 22: Cognitive Wireless RAN Medium Access Control (MAC) and Physical Layer (PHY) Specifications : Policies and procedures for operating in the TV Bands*. Sept. 2006.
- [4] S. Srinavasa and S. A. Jafar, "The throughput potential of cognitive radio – a theoretical perspective," *IEEE Communications Magazine*, vol. 45, pp. 73 – 79, May 2007.
- [5] N. Devroye, P. Mitran, and V. Tarokh, "Achievable rates in cogtive radio channels," *IEEE Trans. Inform. Theory*, vol. 52, pp. 1813 – 1827, May 2006.
- [6] H. Yu, Y. Sung, and Y. H. Lee, "On optimal operation characteristics of sensing and training for cognitive radios," in *Proc. of International Conference of Acoustics, Speech, and Signal Processing*, pp. 2785 – 2788, Mar. 2008.
- [7] H. V. Poor, *An Introduction to Signal Detection and Estimation*. New York, NY: 2nd Edition, Springer, 1994.
- [8] Y. Sung, L. Tong, and H. V. Poor, "Neyman-Pearson detection of Gauss-Markov signals in noise: Closed-form error exponent and properties," *IEEE Trans. Inform. Theory*, vol. 52, pp. 1354 – 1365, Apr. 2006.
- [9] A. Sahai, N. Hoven, and R. Tandra, "Some fundamental limits on cognitive radio," in *Proc. in 42nd Allerton Conference on Communication, Control, and Computing*, (Monticello, IL), Oct. 2004.
- [10] T. Han and K. Kobayashi, "A new achievable rate region for the interference channel," *IEEE Trans. Inform. Theory*, vol. IT-27, pp. 49 – 60, Jan. 1981.